



MATERA 2019 CAPITALE EUROPEA DELLA CULTURA



COMMITTENTE



FERROVIE APPULO LUCANE
Corso Italia nr. 8
70123 Bari

STAZIONE MATERA CENTRALE
RISTRUTTURAZIONE EDILIZIA ED
ADEGUAMENTO TECNOLOGICO

PROGETTO ARCH



Boeri Architetti
tano Donizetti, 4
20122 Milano
+39 0255014101
+39 0236769185

PROGETTO STRUTTURE



SCE Project
viale Sarca, 335/f
20126 Milano
t +39 0270006530
f +39 0271091187

PROGETTO IMPIANTI



ESA Engineering
Foro Buonaparte 76
20121 Milano
t +39 0289151638
f +39 0559029994

COST ANALYSIS



Global Assistance Development S.r.l.
Via M. Quadrio 12
20154 Milano
t +39 0229005672
f +39 0265560517

H	
G	
F	
E	
D	
C	
B	
A	

revisione data
emissione 16.04.2018

livello
PROGETTO ESECUTIVO

elaborato
STATO DI PROGETTO
SCHEMATICI MONTANTI DISTRIBUZIONE
ALIMENTAZIONI PER LA CLIMATIZZAZIONE

commessa
A - MTR

scala formato
- A3 - fascicolo di 2 pagine

n. tavola

PE_I 11 030

DIAGRAM DISPLAY	SYMBOL	LEGEND DESCRIPTION
-#-###		POWER WIRE
— — — —		CONTROL WIRE
- - - - -		REF. PIPE / WATER PIPE
— # —		POWER SIGNAL WIRE

CONT.No PAGE 1 / 1

Appropriate Circuit Protection Device in accordance with local government regulations are mandatory required such as GFI(Inverter type) and WB etc. Please refer the amount of pre-charge and the formula of calculation which is mentioned on the data book.
 1.25mm²(16 AWG) : 1.25mm²(16 AWG) or more. 1.25mm²(16 AWG) : 1.25mm²(16 AWG) or more.
 Grounding required between Outdoor Unit and Indoor Unit(s).

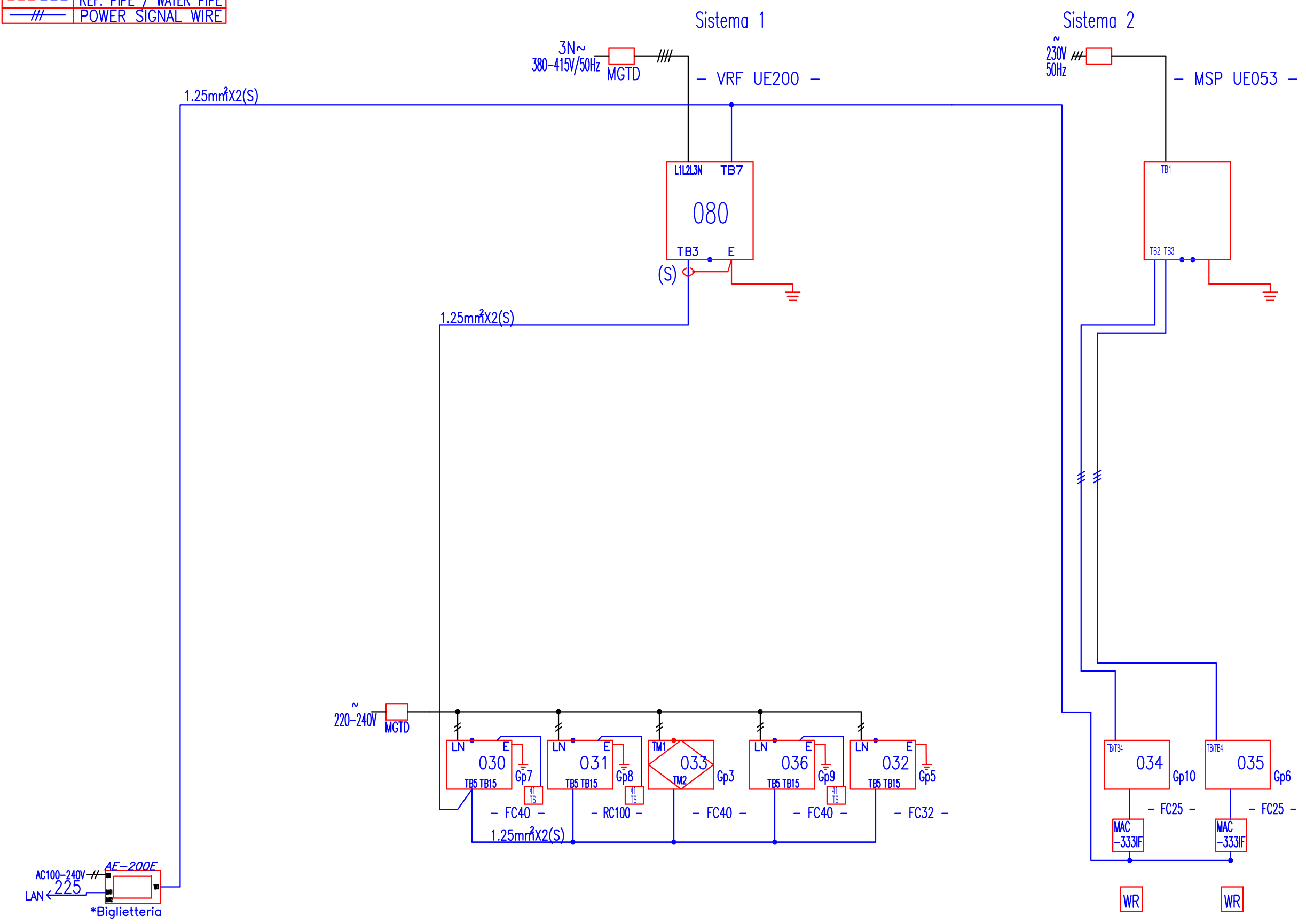

Diagram title area

DIAGRAM DISPLAY	SYMBOL	LEGEND DESCRIPTION
-#- -##		POWER WIRE
—		CONTROL WIRE
- - - - -		REF. PIPE / WATER PIPE
—##—		POWER SIGNAL WIRE

CONT.No PAGE 1 / 1

Appropriate Circuit Protection Device in accordance with local government regulations are mandatory required such as GFI(Inverter type) and WB etc. Please refer the amount of pre-charge and the formula of calculation which is mentioned on the data book.
 $1.25\text{mm}^2(16\text{ AWG}) : 1.25\text{mm}^2(16\text{ AWG})$ or more. $1.25\text{mm}^2(16\text{ AWG}) : 1.25\text{mm}^2(16\text{ AWG})$ or more.

Sistema Sala di attesa

